

HF750

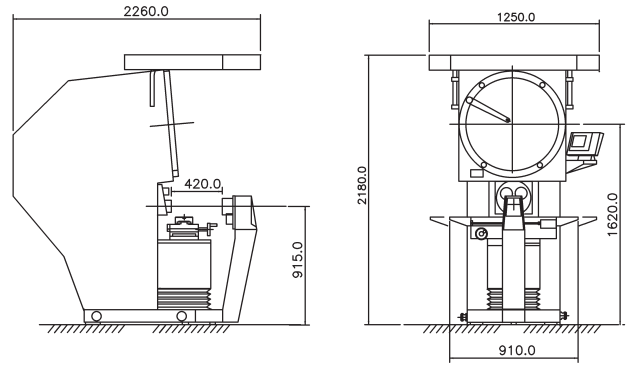

Horizontal Floor Standing Optical Projector

The same exemplary build standards as the HF600, the HF750 benefits from an even larger 762mm (30") screen.

This large fully usable screen sets a new benchmark for levels of clarity and brightness.

Ideal for use over a broad sweep of industries, the HF750 projector is designed and built to satisfy the requirements to measure large work pieces with total precision and efficiency.

- ▶ A compact, robust projector with a large, bright screen for workshop or standard room use.
- ▶ 762mm (30") diameter fully usable screen.
- ▶ Accommodates components up to 150kg (330lb) weight.
- ▶ Available with the full range of Quadra-Chek readout systems.
- ▶ Digital protractor fitted as standard.
- ▶ Machine tool standard workstage powered on both horizontal and vertical axis.
- ▶ Canopy and curtains included as standard.
- ▶ Automatic edge detection option.
- ▶ Single lens or three lens turret options.
- ▶ Comprehensive choice of multi-element precision ground lenses.
- ▶ CNC workstage options.
- ▶ Wide range of ancillaries and options allows specification tailoring and easy upgrading.
- ▶ Accessories include alternative workstage, precision centres, vees, vices etc.

Technical Specification

Starrett®

Screen Diameter

762mm (30") with precision cross lines and calibration markings.

Workstage Support

Power travel knee with variable speed joystick control.

Workstage

Top plate - 630 x 230mm (25 x 9").
Travel - Measuring 300mm (12") horizontal, 200mm (8") vertical, 75mm (3") focus.

Workstage Capacity

150kg (330lb) maximum.
(Evenly distributed).

Workstage Capacity Between Centres

440mm.

Helix Angles

±15° swivelling workstage. Vernier scale 5 minute resolution.

Measurement/display systems

Linear - Heidenhain scales (0.001mm resolution).
Quadra-Chek readout systems with edge sensing option.

Angle - Digital protractor (1 minute resolution).
Quadra-Chek Q-Axis.

Illumination

Profile - Fan cooled, tungsten halogen, yellow/green filter.

Surface - Fan cooled fibre optic system.

Lenses

x10, x20, x25, x 31¹/₄, x50, x100 (x5 to special order).
Single lens mount or 3 lens turret.
2 lens turret mounted condenser system.

Power Supply

110/120/230/240/250V.AC 50/60Hz.
Consumption 5A.

Visit our Web-Site at www.starrett-precision.co.uk

HF750 Specification:	SR121	SR221	SR221e	SR515	SR515 CNC
Rigid steel body	●	●	●	●	●
Standard workstage 300 x 150mm travel	●	●	●	●	●
Extended workstage 500 x 200mm travel	○	○	○	○	○
Anti-corrosion nickel plated workstage top	○	○	○	○	○
Rotary screen & clips	●	●	●	●	●
Handwheel X and Y drive control					
Motorised joystick control	●	●	●	●	
CNC control					●
Angular digital measurement in QC DRO	●	●	●	●	●
X-Y axis only digital readout	●				
Geometric function digital readout		●	●		
Computer with geometric s/ware readout.				●	●
On screen edge sensing			●	●	●
Internal edge sensor			○	○	○
Single interchangeable lens mount	●	●	●	●	●
Dual lens slide					
Multi lens turret	○	○	○	○	○
Fibre optic surface illumination	●	●	●	●	●
On-axis surface illumination	○	○	○	○	○
Single condenser					
Dual condenser slide					
Multi condenser turret	●	●	●	●	●
Yellow/green light filter	●	●	●	●	●
Available lenses (See guide below)	○	○	○	○	○
X5 magnification lens	○	○	○	○	○
X31¼ magnification lens option	○	○	○	○	○
Standard or deluxe support cabinet					
Canopy and curtains	●	●	●	●	●
Work holding accessories	○	○	○	○	○
Magnification checking graticule	○	○	○	○	○
OV² Optical video adaptor	○	○	○	○	○
Screen overlay templates	○	○	○	○	○
Standard ● Optional ○					

Guide to Maximum Component Size (mm)						
Magnification	X5	X10	X20	X25	X50	X100
Field of View	150	75	37.5	30	15	7.5
Working Distance	230	151	101	92	60	48
Max Work Diameter	Half Field	400	400	340	280	160
	Full Field	400	340	240	220	130
Projected Image	Vertically Correct					

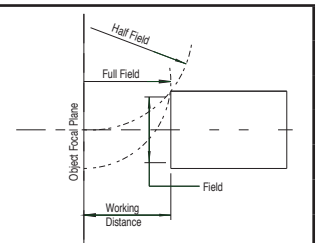

Terminology:

- Working Distance:** Is the distance between the objective lens and the component when the component is in focus.
- Field of View (FOV):** Is the viewing area of the component. A 30mm FOV using a 10x lens would produce a screen image of 300mm.
- Half Field View:** Is the maximum size a component can be projected to the centre of the screen before colliding with the lens.
- Full Field View:** Is the maximum size a component can be projected over the full screen before colliding with the lens.
- Projected Image:** Is how a component is projected onto the screen in relation to its placement on the workstage.